

Decommissioning Environmental Assessment Report  
for Bongkot Project,  
Blocks 15, 16 and 17

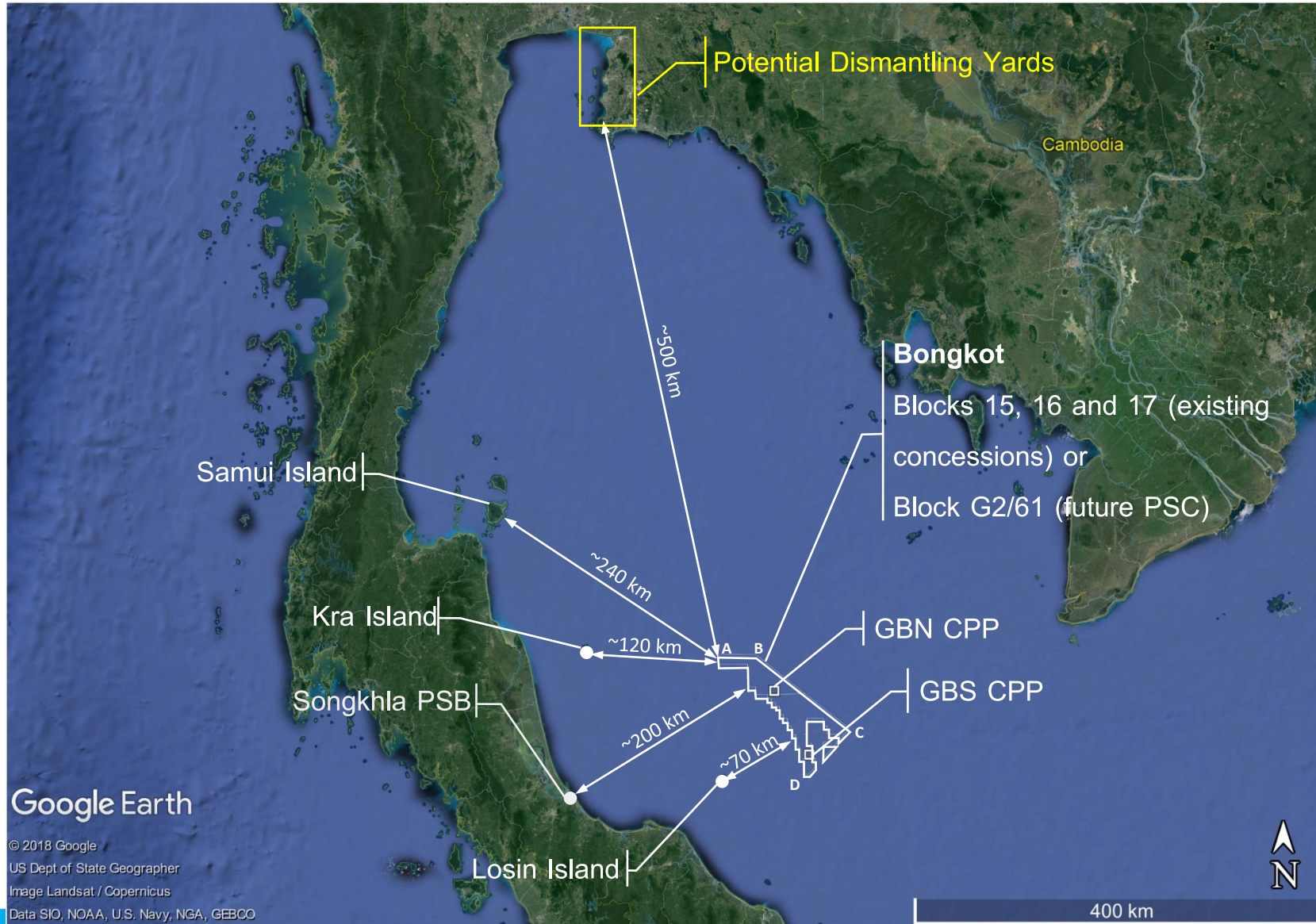

**PTTEP**

# Project Location



# Project Components



- GBN CPP comprises processing platform, quarters platform, riser platform, flare platform, sour processing platform, wellhead platform (WP-1), bridge support platform, and platform connecting bridge
- GBS CPP comprises processing platform, quarters platform, flare platform, and wellhead platform (WPS-1)
- Wellhead platforms
- FSO2, mooring system, riser, umbilical, and buoy
- Subsea pipelines
- Subsea structures (i.e. PLEM/WYE)



# Decommissioning Steps

## Preparation

- Engineering design, planning, and inspection
- Structure cleaning
- Preparation before decommissioning

## Execution

- Removal of processing platform, quarters platform, and other platforms of CPP
- Removal of wellhead platform
- Removal of FSO2 and related structures
- Removal of subsea pipeline
- Removal of subsea structures (PLEM and WYE)
- Management of seabed deposits
- Waste management
- Site survey for dropped object clearance
- Monitoring for post-decommissioning

Activities to be considered  
for decommissioning  
options

# Decommissioning Options for CPP



## Topside – Total Removal

- Onshore disposal by licensed contractor

## Topside (only PP) – Total Removal

- Onshore disposal by licensed contractor
- Reuse

## Jacket – Total Removal

- Onshore disposal by licensed contractor
- Reef at
  - CPP area
  - Potential reeving areas

# Decommissioning Options for Wellhead Platform

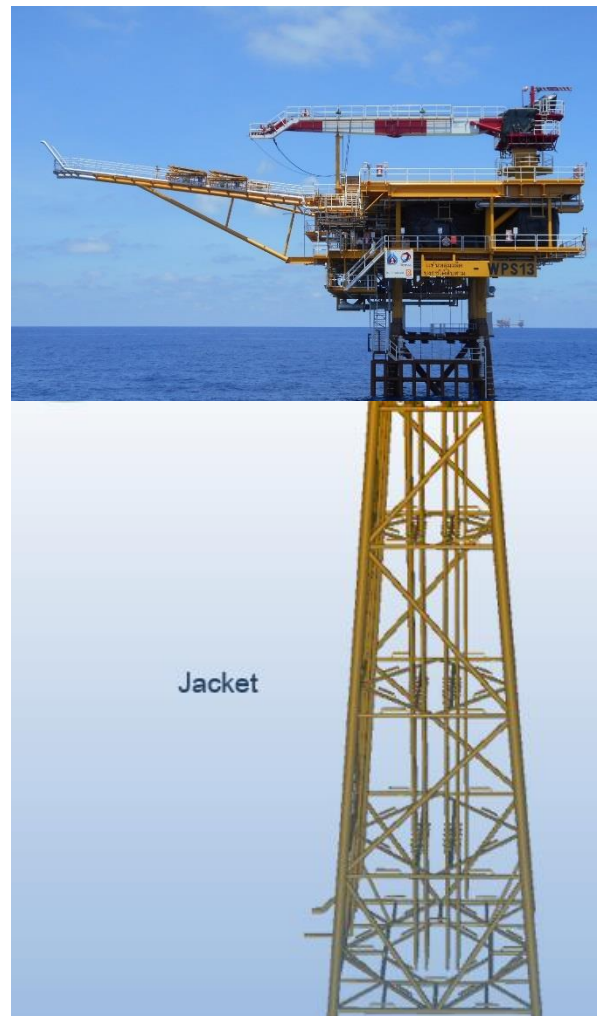

## Topside – Total Removal

- Onshore disposal by licensed contractor
- Reuse

## Jacket – Total Removal

- Onshore disposal by licensed contractor
- Reef at
  - CPP area
  - Wellhead platform location
  - Potential reefing areas

# Decommissioning Activity for CPP and Wellhead Platform

## Topside

- Cut the structures in pieces as determined, and disconnect between topside and jacket, pile and riser above sea level.
- Lift topsides of CPP and WP with crane barge, and lay on another barge.
- Transport topsides to onshore dismantling yard.

## Jacket

- Eliminate sediment inside jacket legs before cutting.
- Cut jacket legs at designed levels.
- Lift and move jacket out.
- Eliminate marine growth at jacket legs.
- Transport jacket for reefing.
- Transport jacket to onshore disposal.

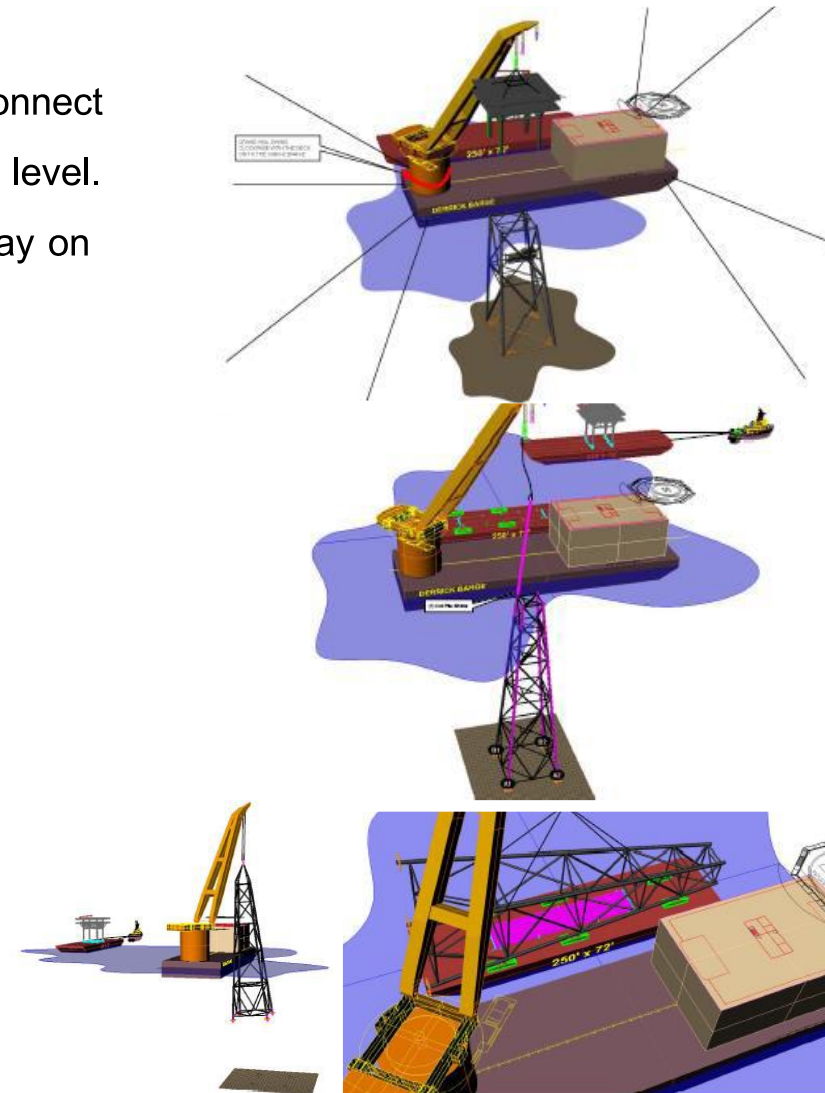

# Decommissioning Options for FSO2 and Related Structures

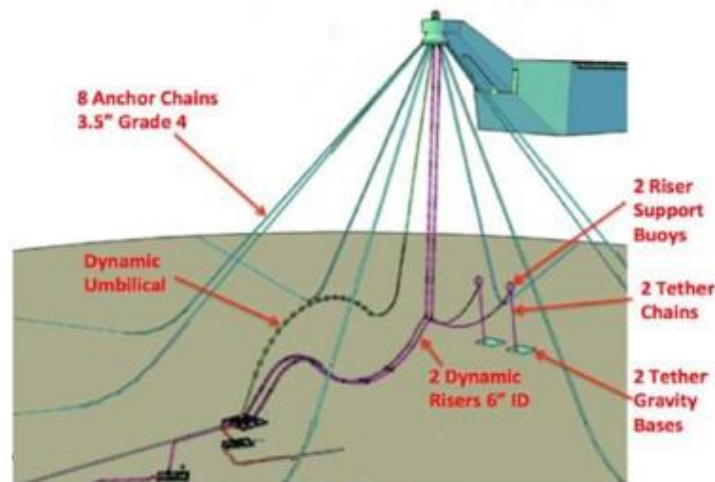

## FSO2 – Total Removal

- Onshore disposal by licensed contractor
- Reuse

## Mooring System – Partial Removal

- Reuse
- Onshore disposal by licensed contractor

## Mooring System – Leave in Place

- Leave on seabed

## Rise, Umbilical, Buoy – Total Removal

- Onshore disposal by licensed contractor



# Lifting and Moving

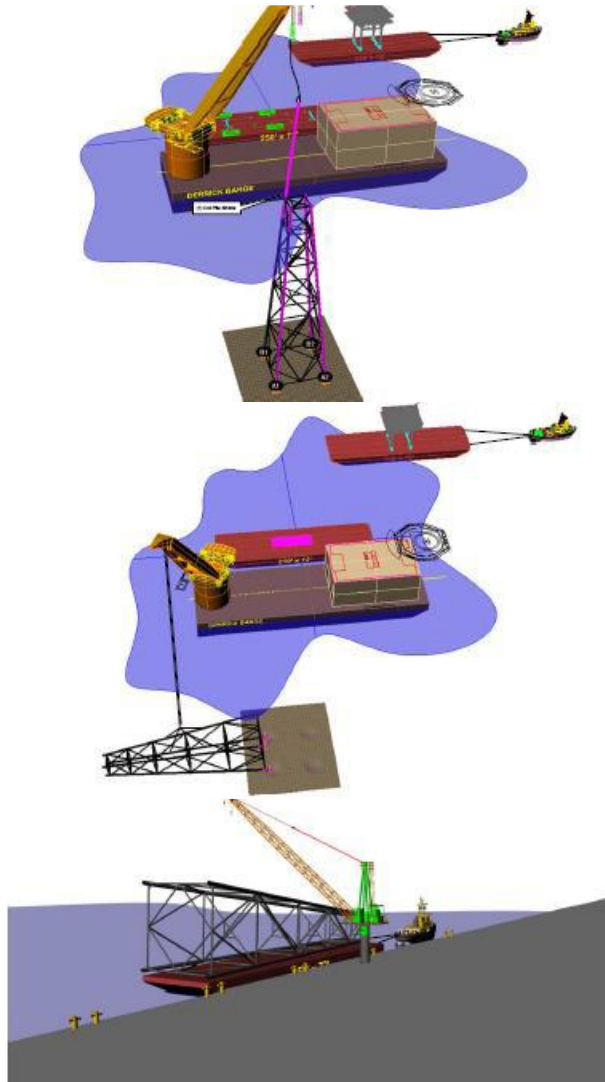

Structure	Option
<ul style="list-style-type: none"> <li>All structures</li> </ul>	<ul style="list-style-type: none"> <li>All options</li> </ul>

## Activities and Possible Impacts

- Decommissioning activities might affect on occupational health and safety, as well as risks to accidental events.

## Key Mitigation Measures

- Follow the occupational health and safety procedures, and prevention control, e.g. training, permit to work, Work instructions for high-risk operations, risk assessment, etc.
- Provide medical emergency response plan, e.g. transfer patient or injured person during emergency case, etc.

# Transport Jacket for Reefing

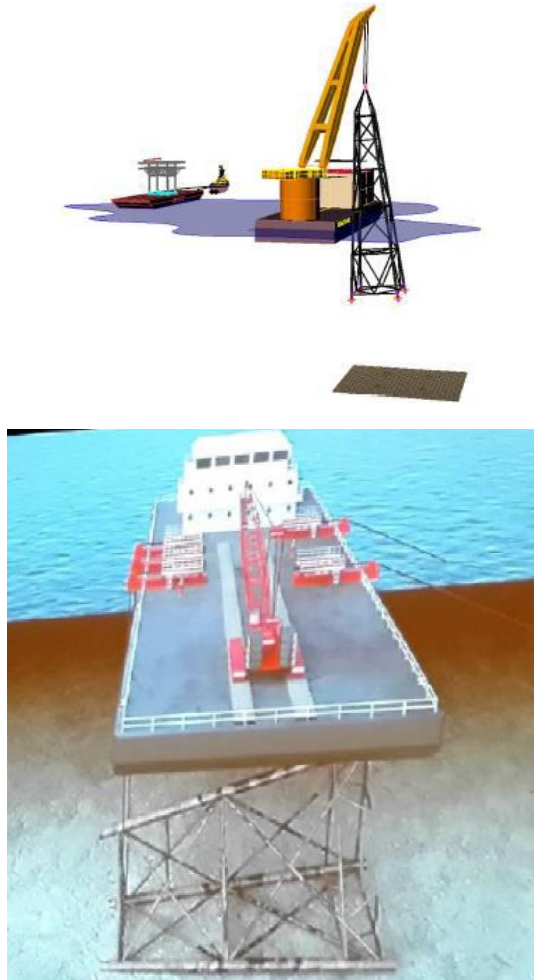

Structure	Option
<ul style="list-style-type: none"> <li>■ PP (only jacket)</li> <li>■ WP (only jacket)</li> <li>■ Subsea structures</li> </ul>	<ul style="list-style-type: none"> <li>■ Artificial reefing</li> </ul>

Activities and Potential Impacts
<ul style="list-style-type: none"> <li>■ Artificial reef might affect on fishery due to disturbance or loss of fishing areas or being obstacle for some fishing gears.</li> <li>■ Transport might affect on commercial navigation.</li> <li>■ Artificial reef might affect positively on marine life and tourism.</li> </ul>

Key Mitigation Measures
<ul style="list-style-type: none"> <li>■ Request permit and follow requirements of reefing permit.</li> <li>■ Develop transport and communication plans in towing during both normal and emergency events.</li> <li>■ Notify details to DMF for coordinating with related agencies ahead of execution.</li> </ul>

# Transport Jacket to Onshore Disposal



Structure	Option
<ul style="list-style-type: none"> <li>All structures</li> </ul>	<ul style="list-style-type: none"> <li>Onshore disposal by licensed contractor</li> </ul>

## Activities and Potential Impacts

- Transporting decommissioning materials to onshore dismantling yard might affect on commercial fishery and commercial navigation.
- Potential impacts are considered temporal. In addition, decommissioning is a return of marine navigation and fishing areas.

## Key Mitigation Measures

- Communicate and keep other vessels warning when encroaching on the 500-m safety area during execution.
- Survey and move fishing gears out as necessary.
- Record coordinates and amount of fishing gears to be move out as well as take pictures. And coordinate via Fishery Association to contact the impacted fishermen, and compensate fairly and properly.

# Transport Marine Growth Waste for Onshore Disposal



Structure	Option
<ul style="list-style-type: none"> <li>■ PP (only jacket)</li> <li>■ WP (only jacket)</li> <li>■ Mooring system</li> <li>■ Subsea structures</li> </ul>	<ul style="list-style-type: none"> <li>■ Onshore disposal by licensed contractor</li> </ul>

Activities and Potential Impacts
<ul style="list-style-type: none"> <li>■ Odour from marine growth waste might pose impacts to public health of nearby communities.</li> </ul>

Key Mitigation Measures
<ul style="list-style-type: none"> <li>■ Select the dismantling yard designed and operated for managing odour from degraded marine growth wastes.</li> <li>■ Limit timing in storing marine growth wastes, and collect them in closed containers during transportation.</li> </ul>

# Decommissioning Options for Subsea Pipeline and Subsea Structures



## Leave in Place

- Leave in place and bury both ends.

## Total Removal

- Reverse installation or cut in pieces, then send for onshore disposal by licensed contractor.



## Total Removal

- Onshore disposal by licensed contractor
- Reuse
- Reef at
  - CPP area
  - Potential reefing sites

# Leaving Pipeline in Place

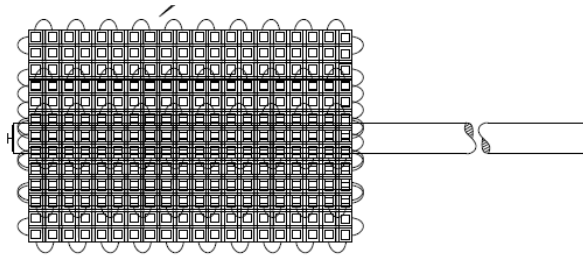
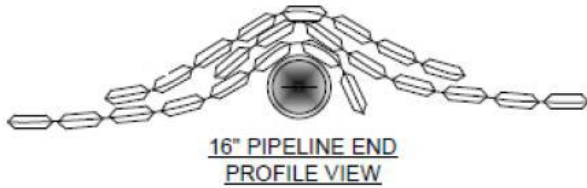

Structure	Option
<ul style="list-style-type: none"> <li>Subsea pipeline</li> </ul>	<ul style="list-style-type: none"> <li>Leave in place and bury both ends</li> </ul>

Activities and Potential Impacts
<ul style="list-style-type: none"> <li>Leaving the pipeline in place, and burying both ends might affect on seawater quality, sediment quality, and benthic community as contaminants in the pipeline might leak out from corrosion.</li> <li>Existence of the pipeline might obstruct future marine utilization. However, the pipeline will sink gradually as time flies.</li> </ul>

Key Mitigation Measures
<ul style="list-style-type: none"> <li>Check content of the contaminants on pipeline surface.</li> <li>Propose contaminant removal method to DMF for approval prior to execution.</li> <li>Notify locations of the left structures to DMF for further coordinating/notify to related agencies.</li> </ul>

# Transport Pipeline and Subsea Structures for Onshore Disposal



Structure	Option
<ul style="list-style-type: none"> <li>■ Subsea pipeline</li> <li>■ Subsea structures</li> </ul>	<ul style="list-style-type: none"> <li>■ Onshore disposal by licensed contractor</li> </ul>

Activities and Potential Impacts
<ul style="list-style-type: none"> <li>■ Eliminating sediment by jetting, lifting pipeline and subsea structures, and cutting joints might disturb the seabed sediment.</li> <li>■ Sediment dispersion during pipeline subsea structure removal might affect environmental quality and marine life around the pipeline route.</li> <li>■ Lifting pipeline from the seabed might pose risks of breakage, which results in occupational health and safety impacts.</li> </ul>

Key Mitigation Measures
<ul style="list-style-type: none"> <li>■ Follow the safety procedures like the lifting.</li> <li>■ Take pipeline strength condition to assess risks before decommissioning execution, then develop detailed work instruction.</li> </ul>

# Decommissioning Options for Cutting Method

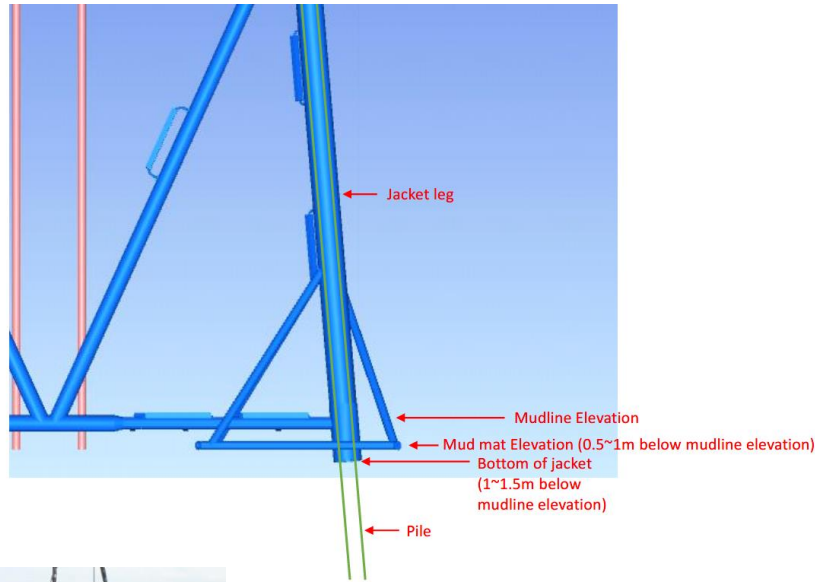

## Levels of Cutting

- Above sea level
- In the seawater column
- At the seabed level
- Under the seabed level

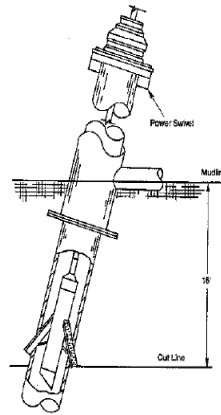
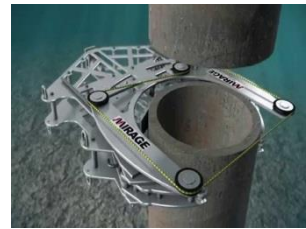

## Cutting Method

- Internal cutting – by water jet or mechanical cutting
- External cutting – by thermal cutting, water jet, mechanical cutting, diamond wire cutting or shear cutting



# Preparation for External Cutting (Under the Seabed Level)



Structure	Option
<ul style="list-style-type: none"> <li>All structures</li> </ul>	<ul style="list-style-type: none"> <li>External cutting under the seabed level</li> </ul>

## Activities and Potential Impacts

- Jetting the sediment before cutting the jacket legs might affect on seabed sediment and benthic community in an area of 100 m from the jetting point, and on seawater quality in an area of 1200 m from the jetting point.

## Key Mitigation Measures

- Use the safe water jetting equipment.
- Study geological data for analysing target area before jetting precisely.
- Avoid jetting operation during monsoon season due to heavy water current and wind.

# Decommissioning Options for Seabed Deposits

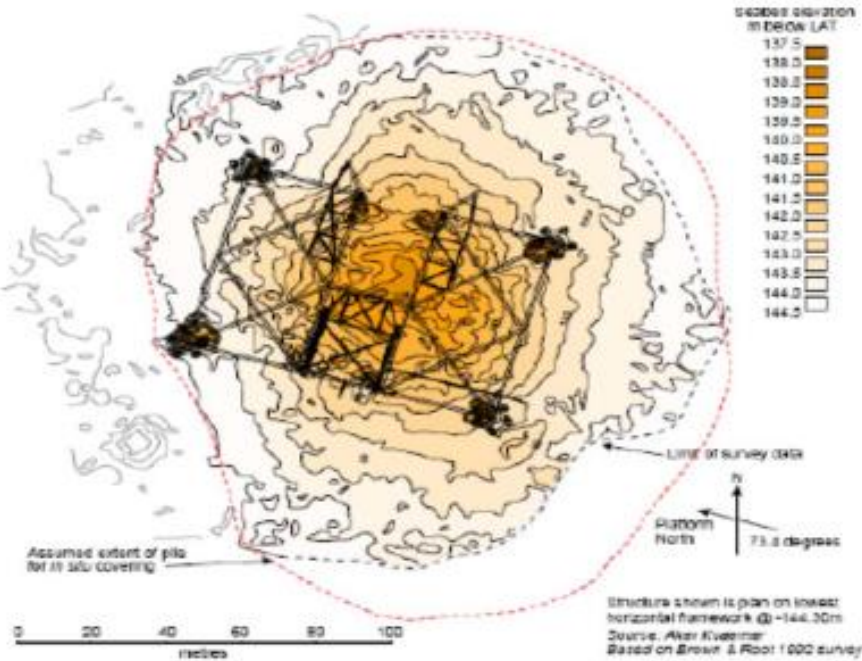

- Leave in Place**
- Leave as it is and monitor natural recovery
  - Capping with proper material

- Total Removal**
- Onshore disposal by licensed contractor

# Leaving the Seabed Deposits in Place and Monitoring Natural Recovery



Structure	Option
<ul style="list-style-type: none"> <li>Seabed deposits around jacket legs</li> </ul>	<ul style="list-style-type: none"> <li>Leave in place and monitor natural recovery</li> </ul>

Activities and Potential Impacts
<ul style="list-style-type: none"> <li>Leave the seabed deposits as it is, and monitor natural recovery, without any addition disturbance</li> <li>Sediment dispersion might occur from other activities, e.g. fishery, natural process, etc.</li> </ul>

Key Mitigation Measures
<ul style="list-style-type: none"> <li>Study boundary and risk on environment to the seabed sediment from previous operations, especially around the processing platform, in order to determine the most appropriate option, boundary, and management method.</li> <li>Follow the environmental monitoring plan during post-decommissioning, and report to DMF.</li> </ul>

# Capping the Seabed Deposits with Capping Material

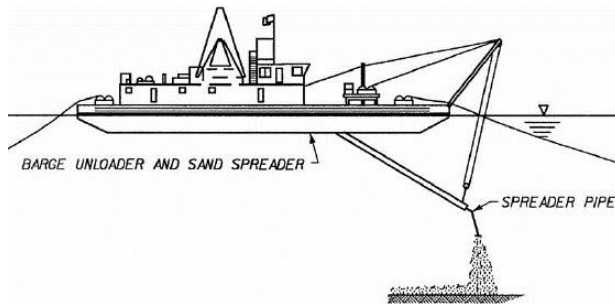

Structure	Option
<ul style="list-style-type: none"> <li>Seabed deposits around the jacket legs</li> </ul>	<ul style="list-style-type: none"> <li>Leave in place and cap with proper material</li> </ul>

Activities and Potential Impacts
<ul style="list-style-type: none"> <li>There has not been recorded about using capping at the real operating sites having the similar water depth.</li> <li>Use non-contaminated capping material which its engineering design is proper.</li> <li>This might affect to other impacts, e.g. dispersion of small particles in water column during deployment and transportation of capping material.</li> </ul>

Key Mitigation Measures
<ul style="list-style-type: none"> <li>Study boundary and risk on environment to the seabed sediment from previous operations, especially around the processing platform, in order to determine the most appropriate option, boundary, and management method.</li> <li>Consider source and deployment method of capping material to suit for its designed thickness and boundary.</li> </ul>

# Sucking/Dredging the Sediment for Onshore Disposal

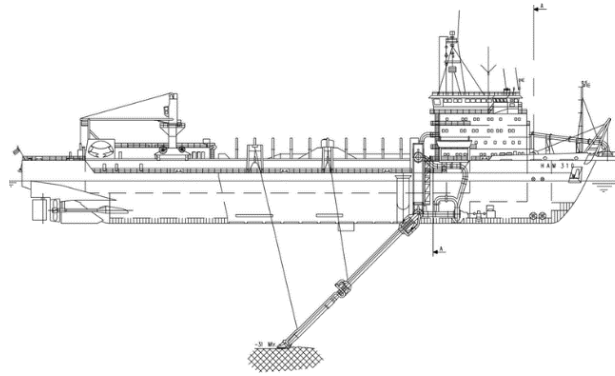

Structure	Option
<ul style="list-style-type: none"> <li>Seabed deposits around the jacket legs</li> </ul>	<ul style="list-style-type: none"> <li>Onshore disposal by licensed contractor</li> </ul>

Activities and Potential Impacts
<ul style="list-style-type: none"> <li>There has not been recorded about the sediment suction or dredging at the real operating sites having the similar water depth.</li> <li>Sediment dispersion might occur in a wider area due to dredging related impacts.</li> <li>This might affect on other impacts, e.g. transportation, water and waste management from dredging activities, etc.</li> </ul>

Key Mitigation Measures
<ul style="list-style-type: none"> <li>Study boundary and risk on environment to the seabed sediment from previous operations, especially around the processing platform, in order to determine the most appropriate option, boundary, and management method</li> <li>Consider the possible suction or dredging method, transportation method, and waste management site to comply with designed boundary and amount of the dredging, and sediment management.</li> </ul>

# Waste Management from Decommissioning Activities

Structure	Option
<ul style="list-style-type: none"> <li>All structures</li> </ul>	<ul style="list-style-type: none"> <li>All options</li> </ul>

Activities and Possible Impacts
<ul style="list-style-type: none"> <li>Collect and transport the wastes generated from decommissioning activities to onshore facilities.</li> <li>Without proper controls, this might affect on public health of who resides near the transport routes and waste management facilities.</li> </ul>

Key Mitigation Measures
<ul style="list-style-type: none"> <li>Hire only the licensed contractors, e.g. waste management and segregation contractors licensed by DIW, etc.</li> <li>Determine that the contractors shall provide procedures or guidelines about SSHE, which complies with all related regulations.</li> <li>Inspect the contractors' operations to ensure that they comply with all related regulations, and PTTEP's SSHE requirements.</li> </ul>

# Abnormal Case : Vessel Crashing

Structure	Option
<ul style="list-style-type: none"> <li>■ All structures</li> </ul>	<ul style="list-style-type: none"> <li>■ All options</li> </ul>

## Activities and Possible Impacts

- Decommissioning activities include vessel operations, and transportation of structures and equipments, which might cause to vessel crashing, then affect to marine navigation, public health, and occupational health and safety issues.

## Key Mitigation Measures

- Communicate and keep other vessels warning to avoid encroaching the 500m safety zone during the operations.
- Provide emergency response plan which covers the vessel crashing case.
- Provide life saving equipments on the project vessels, and regular inspect to ensure the equipments are in good condition and ready to use promptly.

# Abnormal Case : Helicopter Accident

Structure	Option
<ul style="list-style-type: none"> <li>■ All structures</li> </ul>	<ul style="list-style-type: none"> <li>■ All options</li> </ul>

## Activities and Possible Impacts

- Decommissioning activities include helicopter operations for transferring or transporting persons, materials and equipments, which might cause the accident resulting in occupational health and safety issues.

## Key Mitigation Measures

- Provide emergency response plan which covers helicopter accident case.
- Regularly monitor the weather and typhoon forecast.
- Provide life saving equipments on the project vessels, and regular inspect to ensure the equipments are in good condition and ready to use promptly.



# Abnormal Case : Object Dropping

Structure	Option
<ul style="list-style-type: none"> <li>■ All structures</li> </ul>	<ul style="list-style-type: none"> <li>■ All options</li> </ul>
<b>Activities and Possible Impacts</b>	
<ul style="list-style-type: none"> <li>■ Decommissioning activities include moving and transporting structures and equipments by cranes, which might cause to structure/object/equipment dropping, then affect to occupational health and safety issues.</li> </ul>	
<b>Key Mitigation Measures</b>	
<ul style="list-style-type: none"> <li>■ Review steps of structure and equipment lifting and moving with care by using results of Job Safety Analysis.</li> <li>■ Limit lifting route by avoiding lifting through or near the equipments that might pose hazards or damage.</li> <li>■ Designate type and size of packaging to be lifted properly.</li> <li>■ Designate weight of material to be lifted properly to align with crane capacity.</li> <li>■ Inspect the lifting equipment and cables regularly.</li> <li>■ Salvage dropped objects as possible.</li> </ul>	

# Existing Environment Conditions

Refer to results of environmental monitoring during production

- **Seawater Quality**

- Overall seawater quality for all structures complied with Seawater Quality Standard (for Seawater Class I) according to National Environmental Board B.E.2560.

- **Seabed Sediment**

- Overall quality has been involved in past operations, but did not exhibit any toxic to marine life, according to PCD's criteria.

- **Benthic Community**

- Benthic community around all structures was similar to those at the reference station.
- The monitoring stations near wellhead platforms showed presence of Lucinidae as it is the organism living well in the area with high organic content.

- **Plankton**

- Plankton community structure in the vicinity of structures had variations like the reference station.

# Environmental Monitoring Programme during Post-decommissioning

- Monitor around CPP, representative wellhead platforms, and FSO2 only.
- Monitor seawater quality, seabed sediment quality, and benthic community, by using the same parameters with those in the past monitoring.
- Conduct the first monitoring within 6 months after completion of decommissioning activities to be baseline data for further monitoring during post-decommissioning, according to DMF Notification Re: Criteria, Method, and Condition for Preparing Report and Plan for Environmental Management from Decommissioning B.E.2561.

# Environmental Monitoring Programme during Post-decommissioning

## (Cont.)

- Conduct the next monitoring during a 1-3 year period from the first monitoring, by designating details in Final Decommissioning Plan (FDP). The monitoring will end depending upon DMF's approval.
- The monitoring is adjustable depending upon results of the previous monitoring during post-decommissioning.